



iBizSoln

(Web Based -ERP Solution)

**One software to manage your business from
bricks to clicks.**

* User friendly * Affordable * Reliable * Efficient



IBizSoln is web based ERP application for business management system, which integrates facets of the business, including sales, purchase, inventory, accounting, payroll etc. The business environment has become increasingly complex and the marketplace has changed from local to global. Management is under constant pressure to improve competitiveness by lowering operating costs and improving logistics. Organizations therefore have to be more responsive to the customer and competition. **IBizSoln** as a business solution aims to help the management by setting better business practices and equipping them with the right information to take timely decisions.

Development Tools: ASP.net, C#, Crystal report

Hardware & Software Requirements:

Hardware: Server- Hexa core Xeon dual processor with 16GB RAM and 500GB *2 Hard Disk

Client- core 2 duo with 2GB RAM and 320GB Hard Disk

Network: 10/100 Mbps LAN with domain configuration and Broadband width (2 MBPS) connectivity between different locations having static IP

Software: Windows 2008/2012 as server and windows XP/Vista/windows7/Linux as a Client.

Database: MS SQL Server / Oracle

Industries Segments

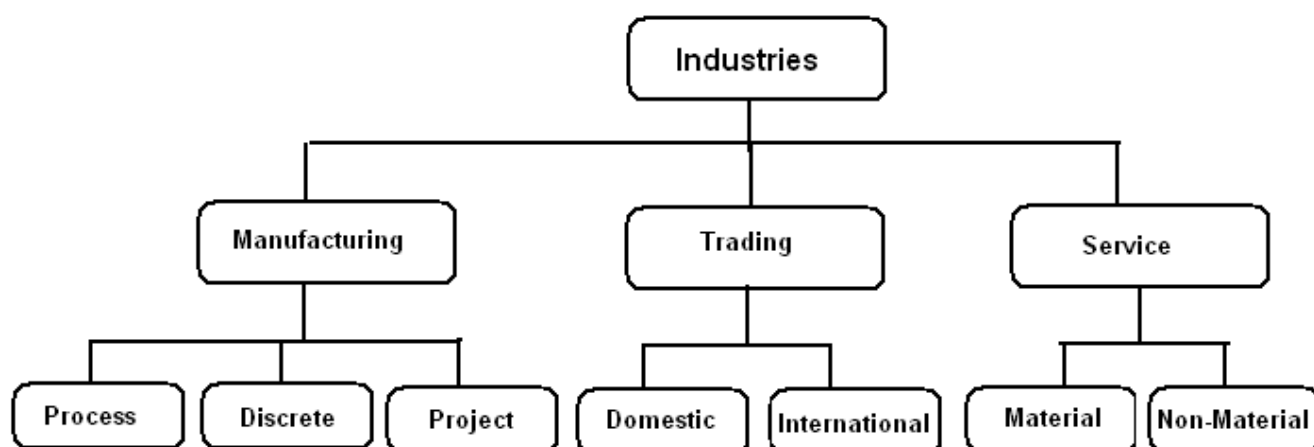

List of Verticals

- Auto-ancillaries
- SPM (Special Purpose Machines)
- Crane & Hoist
- Transformers
- Process Industry
- Chemicals & lubricants
- Molding
- Electroplating
- Tools & Dies
- Assembling Units
- Capital Projects
- Electronics
- Electro mechanical



Workflow of IBizSoln

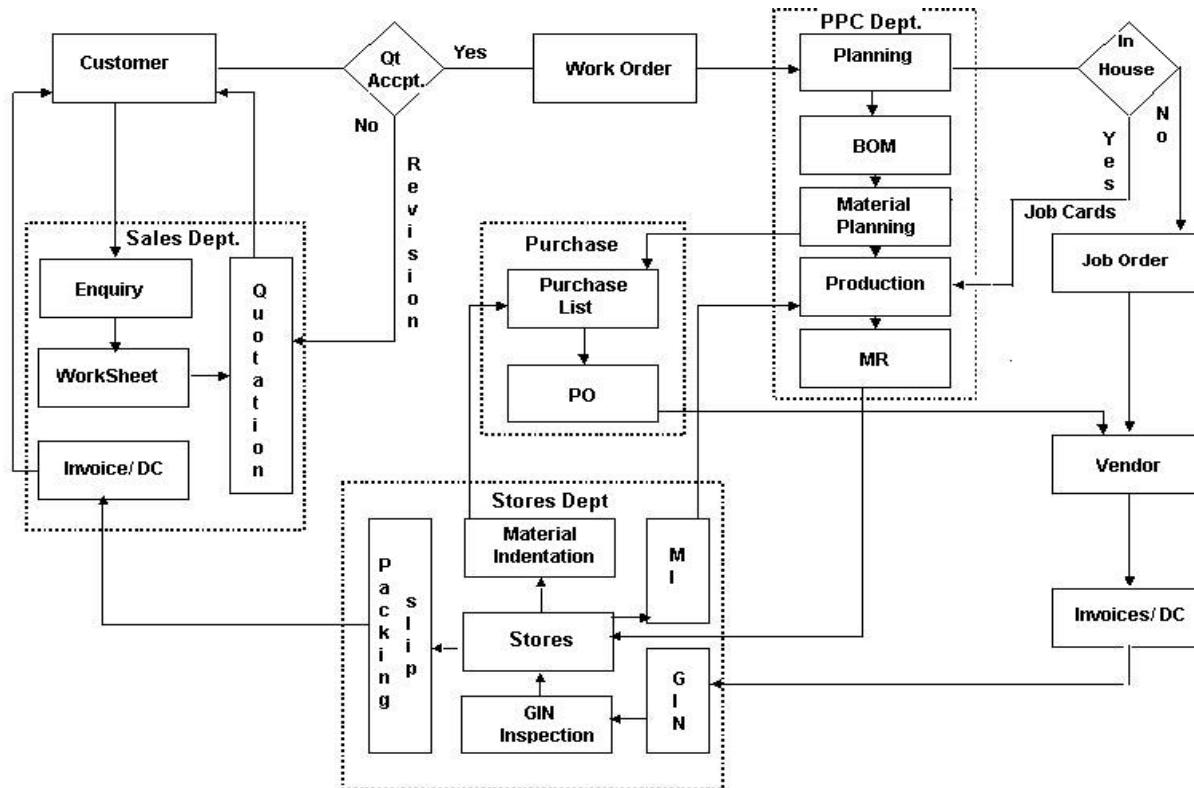

List of Modules (Basic)

Sr No	Modules	Sr No	Modules
1	References	10	Excise & Tax Management
2	Front Office	11	Material Planning
3	Administration	12	Production Management
4	Utilities & Internal Messaging	13	Quality Control(RM/FG)
5	Sales & Marketing	14	Payroll (Pay Process)
6	Dispatch	15	ERM(Employee Relationship Management)
7	Purchase	16	Complaint Management
8	Inventory	17	MIS
9	Financial Accounting		

List of Modules (Advance)

Sr No	Modules (Optional)	Sr No	Modules (Optional)
18	Sales & Marketing (Advance)	31	Export & Import
19	Purchase (Advance)	32	Asset Management
20	Inventory (Advance)	33	Advanced Finance Management- (Budgeting, Forecast, RFC, Ratio Analysis etc)
21	Material Planning (Advance)	34	Capital Project Management
22	Production Management(Advance)	35	Security & Gate Pass
23	Quality Control(WIP)	36	Service & Installation Management
24	Production scheduling & Capacity Planning	37	Logistics & warehouse Management
25	Plant and machinery Maintenance	38	CRM/SCM
26	Estimation & Costing	39	Dealer Management
27	Project Budgeting & Tracking	40	Tender Management
28	HR Management (Recruitment/ leave/ Performance Appraisal)	41	Event Management
29	Payroll (Attendance & Income Tax)	42	Resource Management
30	Document Management	43	Advance MIS



Value Added Services (Optional)

Sr No	View	Sr No	View
1	Tally Integration	6	Mobile Apps Development (Android ,iOS)
2	Data Entry(500 BOM/500 customer-vendor/10000 Items)	7	Integration with Third Party applications and Machines
3	Barcode & RFid Integration	8	Customization
4	Business Intelligence	9	Additional 5 Users slab
5	e - business (Integration with web portals, payment gateways	10	Additional Location Implementation

List of Alerts

Sr No	Alerts-Basic	Sr No	Alerts-Advance
1	Diary	51	Pending Enquiries (Hot)
2	Action for Correspondence	52	Pending work order -Services
3	Today's Appointments	53	OA canceled/short closed –Last 7 days
4	Wish Reminders	54	Quotation rejected/canceled –Last 7 days
5	Monthly Returns-Status	55	Quotation Amended (Last 7 Days)
6	User Login Details(last 10 logins)	56	OA amended (Last 7 Days)
7	Holidays for this Month	57	Invoices canceled-Last 7 Days
8	Pending Approvals	58	Payment receipt from customer-Last 7 days
9	Customer Receipt Summary	59	Debit/ Credit Note Raised - Last 7 days
10	Defaulter Customer Receipts	60	Advances received - Last 7 days
11	Supplier Payment Summary	61	Advances Paid - Last 7 days
12	Defaulter Supplier Payment	62	Vendor enquiries Generated --Last 7 days
13	Today's Enquiries	63	New Prospective party generated --Last 7 days
14	Pending Enquiries (status Not Updated)	64	New Prospective Item generated --Last 7 days
15	Pending Quotation (status Not Updated)	65	PO Amended (Last 7 days)
16	Pending OA (sales Order)-Work order Not generated	66	PO canceled/short closed –Last 7 days
17	Pending OA (sales Order)-Not Dispatched	67	Party Blocked (Last 7 days)
18	Pending Work Order(Dispatch Not Done)	68	Purchase Invoice On Hold
19	Pending Dispatch Clearance	69	Pending work order for BOM
20	Today's Dispatch Schedule	70	BOM revised –last 7 days
21	Pending Invoice(Account Import)	71	Projects Revised-Last 7 days
22	Pending Invoice for Payments	72	Below Reorder Level Items - In-house
23	Pending Purchase List (PO Not Generated)	73	Pending Projects(Planning Not Done)
24	Pending Purchase Order (GIN not Done)	74	Pending Production –WIP (QC Not Done)
25	Pending GIN(QC Not Done)	75	Pending Rework Indent
26	GIN Without Excise Invoice No.	76	Pending Projects-Allocation Not Done
27	Pending GIN (Statuary forms like C,H)	77	Pending Projects-MR Not Done
28	Pending GRIN (Stock Updation Not Done)	78	Pending Projects-MI Not Done
29	Pending GRIN(Rejection Note Not Done)	79	Pending Projects-Budget Not Allocated
30	Pending Rejection Note (No Action)	80	Projects-Crossing Budget Limits(70/80/90/+)
31	Pending GIN (Invoice Not Done)	81	Projects delayed-not completed
32	Pending Purchase Invoice-Bill (Account Import)	82	Projects canceled/short closed –last 7 days
33	Pending VC(GIN Not Done)	83	Product diversion–last 7 days
34	Pending VC (Item Out Not Done)	84	Assets added-last 30 days
35	Pending MR (Material requisition Not Issued)	85	Complaints received--last 7 days
36	Below Reorder Level Items	86	Complaints not attended
37	Pending Production (PD Not Done)	87	Pending AMC renewals



38	Pending Production (QC Not Done)	88	Items/stock expired (Shelf life)
39	Pending Production (Stock Updation Not Done)	89	Negative stock
40	Pending Bills-Payment Advice	90	Items-location not allocated
41	Pending Bill due for Payment-7 Days	91	Drawings revised-last 7 Days
42	Expected Receipts in 7 Days	92	New recruitment-last 30 days
43	Employee- attendance not freezed	93	Employees left- last 30 days
44	Employee- Pay not processed	94	Employees on leave-Next 7 days
45	Customer advance not adjusted	95	Interviews scheduled for next 7 days
46	Supplier advance not adjusted	96	Employee-documents for IT not submitted
47	PDCs Received- Next 7 days	97	Pending Employee-Increment
48	PDCs issued-Next 7 Days	98	Pending Employee-Confirmation
49	Vendors unapproved	99	Pending Appraisal Approval
50	Pending LR/statuary forms	100	Machine maintenance-Next 7 days

MIS Dashboards

- Inventory
- Production
- Finance
- HR & Payroll
- Asset
- Approvals

MIS Views

Sr No	View-Basic	Sr No	View-Advance
1	Attendance	21	Order View Analysis
2	Customer Summery	22	FG/RM Quality analysis
3	Sales Analysis (Party-Item)	23	Tax analysis
4	Daily Progress Chart (Sales)	24	WIP analysis
5	Customer Delivery Rating	25	Vendor grading (Rating) analysis
6	Enquiry Status	26	Purchase rejection /rework analysis
7	Purchase Summary - Purchase category	27	Sales team performance analysis
8	Daily Dispatch Status (Invoice)	28	Cash flow analysis
9	Reconciliation of Sale / Purchase New	29	Approval delayed analysis
10	Consumption statement (Quantity) Yearly	30	Production cost analysis
11	Sales Analysis (Party)	31	Employee performance analysis
12	Customer Aging Analysis	32	Complain analysis
13	Vendor Aging Analysis	33	Production status analysis
14	Quotation Status	34	Machine Maintenance analysis
15	Order Vs Sales (Value)	35	Capacity analysis
16	Party wise Summary Purchase-Year	36	Asset analysis
17	Material Inward Status	37	Capital project analysis
18	Item Production Details	38	Profitability analysis
19	Stock Status-Location wise	39	Projection v/s sales analysis (product/party)
20	Consumption Statement (value) Yearly	40	Non moving stock analysis



General Features (Common)

- Fully functionally integrated
- Cross level Securities
- Menu driven & easy to use
- Internal Messaging
- Password security
- Multiple Search Facility & Powerful Query Builder
- User wise Date Recallers with Appointment and Schedule Settings
- User wise alerts for various activities like PO schedules, dispatches, ROL etc
- Backup and Recovery Facilities
- Intimation through Messaging and Business Alert System that focuses on Networked Employees, Vendors and Customers
- Online mailing of documents like Purchase Order, Invoices, Work Orders etc. while creation itself
- Conversion of Reports into PDF, MS-Excel, MS-Word
- Maintenance of History files with Recovery facility
- Maintenance of Log files
- Powerful report drafting tool to generate reports by user
- Amendments & revision log
- Intelligent Data Entry Interface

Features (Advance)

- Comparative Analysis
- Multi Location & multi currency facility
- Customizable User Interface
- User Defined Code Generation
- Multi Level Approval Matrix for documents.
- Graphical report generation for various analytical data
- Customers & Suppliers can view online Order & Payment status
- Dashboard to show online information.
- Barcode generation support.
- Integration with attendance devices

Statutory Reports	
Excise	Taxation (VAT/CST/LBT etc)
<ul style="list-style-type: none"> • Form RG-1 (Daily Stock Status) • Stock Register • Sales Book with Excise details • Personal Ledger Account (PLA) • Excise Assessable Value (Report) • Excise Product wise Report • RG1/RG23AI/RG23AII/RG23CI/RG23CII • ER1/ER4/ER5/ER6/ER7/ER8 • ARE-1/CT-1 • Service Tax Part-I (Record of CENVAT credit allowable on Input/Services) • Service Tax Part-II (CENVAT credit utilized on Input/Services) • Service Tax Part-III 	<ul style="list-style-type: none"> • Sales Tax / Purchase Tax Summary • Sales Tax Account Registers & Vat Returns • Sales Tax Forms Receivable / Issuable & Reminders • Service Tax, F.B.T., T.D.S,LBT • Party Wise VAT/CST Summaries
TDS & Income Tax	HR & Payroll
<ul style="list-style-type: none"> • TDS deduction and Payments • Advance tax payment • 24Q/26Q/27Q/27EQ 	<ul style="list-style-type: none"> • PF Statement (3A, 6A, 12A) • P.F. Form 5 & 10 • ESIC Form 6 & 7 • Form 16



Financial Accounting	Export & Import
<ul style="list-style-type: none"> Bank statements Stock statements Profit & Loss Balance sheet (Schedule VI) Depreciation register Debtors & creditors Statement 	<ul style="list-style-type: none"> Certificate Of Origin Shipping Bill G.S.P/G.R. Form AR-4 /AR-3A/ARE1 Bank Certificate Daily Stock Register CT3 Register B17 Bond Register Export /Import Register
Miscellaneous	
<ul style="list-style-type: none"> CGST/SGST /IGST 	

Modules Wise forms/Transaction

1.References	
Features	Reports
<ul style="list-style-type: none"> Profit Center/Branch Department/Sub Department Currency/Currency Conversion Country/State/District City/Location/Region/Zone UOM (Unit of Measurement)/UOM Conversion Banks /Branches/ Accounts Term Condition/Term Condition group Operations/Check List/Transport Master Tax /Tax Group General/ Sales /Production Parameter QC Parameter/QC Parameter Group Tariff-Heading Master Packing /Packing Conversion 	<ul style="list-style-type: none"> Branch Info/ Branch Register Department Register Currency Register Bank info/ Register Transport Register Tax info / Register

2.Front Office	
Features	Reports
<ul style="list-style-type: none"> Daily Exchange Rate (Currency/Material) Front Office Inward Front Office Outward 	<ul style="list-style-type: none"> Exchange Report Inward Register Outward Register

3. Administration	
Features	Reports
<ul style="list-style-type: none"> Role/Right /User Master Report Right/ Alert Right Master Audit History/ Mail Audit History CRM/SCM Right Master Delete/Close/Cancel Transaction Document Authorization(Approval Matrix) Email setting and content management 	<ul style="list-style-type: none"> Role Register User Register/List of Users Log Register Mail Register Transaction Register

4. Utilities & Internal Messaging	
Features	Reports
<ul style="list-style-type: none"> User wise GUI setting Correspondence(Inward/Outward) Personal Contacts/Daily diary Reminders/Company Calendar (Holidays) Appointment allocation Item Search/Unit convertor Internal Messaging 	<ul style="list-style-type: none"> Correspondence Register Diary Holiday List Daily Appointment List



5. Sales & Marketing	
Features	Reports
<ul style="list-style-type: none"> • Party Master (Customer/Prospective Customer) • Enquiry • Quotation • Sales Price List • Performa Invoice • Order Acknowledgment • Order Acceptance • Order Acceptance Schedule • Monthly sales Plan • Work Order (Direct Dispatch) • Credit Note • Sales receipts • Sales Returns Tracking • Order (OA) Tracking • Customer reconciliation(Job /Processing order) 	<ul style="list-style-type: none"> • Party Info/ Register • Enquiry Info/Register • Enquiry Analysis Reports • Sales Price Register • Quotation Reports /Register • Product wise Hit Ratio Analysis • OA /OA schedule Register • Work Order Register • Order Acceptance- Dispatch Detail • Sales register • Order Executed History • Party Outstanding & Ageing Report • Actual V/s projected sales • Performa-Invoice Report/Register • Orders History/ Backlog/ Received • Price Variation Report • Credit Note Report/Register • Sales Returns Register • Customer job Register • Customer Material reconciliation Report

6. Dispatch	
Features	Reports
<ul style="list-style-type: none"> • Packing slips & List • Dispatch Schedule (Planned Vs Actual) • Dispatch Instructions & check List • Daily Dispatch • Dispatch Clearance • Delivery Challans /Tax Invoice • Commercial /Supplementary / Rejection /Export Invoices • Update Invoice details(LR/H-C forms etc) • ASN file generation • LR Slips • Products Stock Adjustments • Fleet Maintenance • Sales Return • Dispatch Overhead Costing • Export- Packing hierarchy , Documentation • Containers (Boxes/ Bottles / Cylinders) Accounting 	<ul style="list-style-type: none"> • Dispatch Register • Schedule VS Dispatch Register • Packing List Register • Packing slips • Sales return register • Tax invoice Reports/ register • Supplementary invoice Report/ Register • Rejection invoice Report/ Register • Daily dispatch register • Dispatch clearance Register • LR register • Export packing list • Export documents like Packing lit/slip,CT3, ARE1, export Invoice etc • Fleet register • LR Register • Sales Returns Register • Statuary forms register like C, H ,F etc

7. Purchase	
Features	Reports
<ul style="list-style-type: none"> • Party Master (Vendor /Prospective vendor) • Purchase Order (material/capital/Services) • Purchase Order (Labor/ Job work) • Purchase Order Schedule • Purchase Invoice • Update Purchase Invoice (LR/H-C forms etc) • Debit Note • Purchase Rejection Return • Service Charge Adjustments • Vendor material reconciliation • Vendor Aging • GIN Costing (Landed Cost) 	<ul style="list-style-type: none"> • Vendor Info /Register • PO Report/ PO Schedule Register • Pending PO Statements (Value/vendor/item) • Material Schedule statements • PO Pending on Rejected Material • Pending Payment Register • Landed Cost Report • PO Amendment Details • Daily Purchase Report • PO Status Report • Vendor wise Order Value Register • Excise Duty loss at PO stage • Variance GIN & Bills • Statuary forms register like C, H ,F etc



8. Inventory	
Features	Reports
<ul style="list-style-type: none"> • Item Category • Item Sub Category • Item Group • Item Master • Opening Stock • GIN • Stock Update • Stock Conversion • Material Requisition • Material Issue • Material Adjustment • Vendor Challan(Excise/Non Excise) • Material Transfer & return • Stock Valuation • Bin Card 	<ul style="list-style-type: none"> • Item category/ sub category/group Register • Item Info/ Register • Stock report/ Register • Stock crossing reorder level • Under Inspection stock report • Non-moving stock item report • Supplier wise material receipt • Item wise material receipt • Statements of Excess/ Shortage/ Rejected Materials • Material requisition slip/ Register • Material issue slip/ Register • GIN register • Consolidated statements of Receipts and Issues • Bin Card • Rejection Report /Discrepancy Register • Pending Requisition • Stock Valuation statement Stock Ledger • Rec/Iss/Adj/Rej/Ret Status • Returnable Issued Material Register • Vendor Challan Report/ Register • Inventory Statement For Bank • Rejected Material Sent Out • Stock Adjustments register

9. Financial Accounting	
Features	Reports
<ul style="list-style-type: none"> • Accounts Group/ • Ledger Master • Narration Master • Op Balance FA • Dimension Group / Sub Group Master • Dimension Master • Import Ledger • Import Transaction/voucher Posting • Bill-Passing Advice / Audit – Report Generation • Post-Dated Cheques (Payments / Receipts) • Suspension of Accounts • Advance Payment Requisition • Concession Form Types • Party Advance Adjustment • Journal/ Contra Entry Voucher • Cash Payment And Voucher • Cash Receipt And Voucher • Bank Payment And Voucher • Bank Receipt And Voucher • Bank Reconciliation • Foreign Exchange Pur. / Sales • Cheque Book Master • Cheque Issue/ Printing/Cheque Status • Advance Cheque issue to Supplier • Advance Cheques received from customers • Pending advance cheques adjustment • Un-cleared cash (Advance Cash) for Expenses • Cheque Dishonor • Payment Advice • Cash Book • Cash Flow Master • Trial Balance/Balance Sheet/Profit & Loss 	<ul style="list-style-type: none"> • Day Book • Bank Book • Journal Register • Debit/Credit Note Register • On Account Report • Sub Ledger • General Ledger Trial Balance • Sub Ledger Trial Balance • Bill Wise Opening Balance Outstanding • Cost Center Activity / Analysis Report • Profit & Loss Statement • Bank reconciliation • Cash Book • Account Code Wise Summary • General Ledger • Drs. Age wise Analysis • Crs. Age wise Analysis • Tax Wise Report • Balance Sheet • Cash flow/Funds Flow • Bank Payment Details • Statutory Reports • Provision Trial Balance • Profit & Loss Statement • Divisional P&L Statement • Balance-Sheet • Schedule Report • Consolidation Reports • Group Chart (Layout) • Debtors/Creditor Register • Tax deducted At Source (TDS) Register



10. Excise & Tax Management	
Features	Reports
<ul style="list-style-type: none"> Opening Taxes Tax group Processing Tax Group Adjustment Tax Challan processing like TR6 Challan Cenvat Credit (ModVat) Cenvat Debit Services Tax Credit/ Debit PLA (Personal Ledger Account) Sales Return Entry Posting to Part I & Part II and Annexure like 18, 19, 21 Duty Liability & Balances State/Country wise Tax Reports & Registers TDS Processing 	<ul style="list-style-type: none"> DSA (Daily Sock Account) Report CENVAT I & II Report TR6 Challans PLA Register Excise 4-5(a) Register ER1 Register Form ER 3 A Annexure IV (Stock Register of goods sent for Processing/ Job work) Annexure V (Account of receipt of raw material, inputs & SFG) Annexure II (Challans for job works) Annexure VI (Subsidiary Challans for job work) Form RG 16 ARE1 Register ER1 Register VAT Register TDS Register LBT/Octroi Register Cenvat – Credit taken through GIIR

11. Material Planning	
Features	Reports
<ul style="list-style-type: none"> Sub Assembly Multilevel Technical BOM (Standard/ Project) BOM amendments/Revisions Material Requirement Planning (Consumable)-MRP-I Generate Projects(lots) Creating Stores and Purchase Indents Auto Indent (Work order based) Bought out schedule(PL) Project Master (With OA, W/o OA) Reorder Level based planning 	<ul style="list-style-type: none"> Sub assembly Report BOM printing BOM analysis Reports BOM Amendment Register Material Indent Registers Bought-out (PL)register Various Planning Reports(MRP-I)

12. Production Management	
Features	Reports
<ul style="list-style-type: none"> Process/Operation Master Production Slip/Indent Material Requisition Sub Assembly /Finished goods Production Material Transfer(Return to store) Product Declaration 	<ul style="list-style-type: none"> Daily Production schedule register Production Report Work Order Vs Produced Consumables Consumption Register Daily production Register

13. Quality Control(RM/FG)	
Features	Reports
<ul style="list-style-type: none"> Item Standards & Specifications QC parameter master Non conformance/ Rejection master GRIN(QA-RM) Preparation QC Parameter Wise testing Sample Base Testing QAD (QA-FG) Preparation Supplier Quality rating Test Certificate Pre-Dispatch Inspection Dispatch Clearance Rejection Note 	<ul style="list-style-type: none"> Daily inspection (QA) report /register GRIN (QA-RM)Register QA-GF Reports/Register TC comparison Raw Material Standards and Specifications register Product Standards and Specifications Product Inspection Data Raw Material rejected during a period Products rejected during a period



14. Payroll (Pay Process)	
Features	Reports
<ul style="list-style-type: none"> • Employee Profile • Customize Emoluments Head • Emoluments, Deductions & Perquisite Maintenance • Holidays • Basic Type Master • Designation Master • Perquisite Master • Union /Rebate /Health/Category/ Route Overtime / In-Out / Site/ Skill Master • Tax Slab • Time sheet Management • Payroll Processing • Employee Transfer/Promotion/ Increment maintenance • Shift Allocation (Fixed / Rotation) • ESIC/PF/PT • Bonus (Production/ Festive) • LIC & Other Insurances • Loans • Final Settlement • Payroll Accounting - Basic • Leave Encashment • Priority Table for deductions • Multiple LIC's, ULIP, NSC's policies • Bank Advice, Cheque Printing Module • Location by Cost Centre wise salaries JV for multi-location company • Increment Arrears / Rate revision • Imprest amount released and adjustment • Loans Issued • Loans Refunded outside Salary • Loan Enhancement 	<ul style="list-style-type: none"> • Employee Profile Report • Employee register • Time sheet report • Pay slips • Pay Registers • OT Summery • Earning & Deduction Registers • Advances & Recovery Statements • LIC & Loans Recovery Statements • PT Statements • Bonus statements • Voucher Printing • ESIC summery & Statements • PF Statement (3A, 6A, 12A) • Bank Salary Statement • Cash Salary Details • Bank Account wise Payment Report • Department wise Payroll Summary • Overtime Report • PF Recovery Statement • Professional Tax Recovery Statement • ESI Recovery Statement • Canteen Deduction Statement • Welfare Recovery Statement • Bus Fare Recovery Statement • Grade wise salary Statement • Employee Not confirmed report • Employee Joined In Particular Month • Left Employee Status • Employee Retirement Status • Employee Wise Leave Balance • Blood Group Wise Report • Grade Wise Manpower Status • Department Wise Manpower Status • Gratuity Statement • Net Salary & Wages Statement • Deduction Excess Earning Report • LTA Statement/ • Medical Statement • Payroll Summary • P.F. Form 5 & 10 • Employee List with specific Earning / deduction • Form 6 & 7(ESIC) • Transfer & Promotion Letters

15. ERM(Employee Relationship Management)	
Features	Reports
<ul style="list-style-type: none"> • Employee code Login • View of ESIC/PF statements • Attendance verification and freezing • Salary view • Leave application • Official Tour application(On duty) • Gate pass • Perquisite entry (Traveling, mobile etc details) • Leave approval 	<ul style="list-style-type: none"> • ESIC/PF statements Reports • Salary slip printing • Leave application printing



16. Complaint Management	
Features	Reports
<ul style="list-style-type: none"> Complaint booking Complaint Allocation Complaint status update 	<ul style="list-style-type: none"> Complaint booking Info/Register Complaint allocation register Complaint status register

17. MIS	
Reports	Reports
<ul style="list-style-type: none"> Customer Register-closed Customer Register Customer Register-Prospective Enquiry Register (Product/zone/sales executive/export) Enquiry Register (Canceled/regret) Enquiry Register (Converted) Enquiry Status Summary-(Quantitative) Quotation Register (Product/zone/ sales executive/export) Quotation Register (converted/regret) OA Register (Product/ zone / sales executive/ export) OA status Register OA Register Item Wise-(Completed/ Pending)) OA Schedule Register OA Dispatch Status Register OA Register (work order not generated) Work Order register-(pending/dispatched) Dispatch Clearance register OA VS DC status Dispatch register Performa Invoice Register Bank Guarantee Register Sales Report-(item –Packing wise) Sale Register (export/service) Sales Summary Report Sales Statement Item wise Sales Statement Sales Statement Tax wise Sales Statement (Excise) Customer-Wise VAT Sales Report Customer-Wise Debit Note Or Credit Note Customer-Wise VAT Debit Note Or Credit Note Sales Report (A/C Party) Customer Wise Product Rate Detail Customer Outstanding register Customer aging register Customer payment summery Defaulter Customer Payment Summery Item register Prospective Item Register Items revised/closed (block) register Item Rate change Register Stock Register (location/section/packing) Bin Card Stock Value Register MR Register (employee/item) MR Register(pending/short closed) MI Register MA(Adjustment) Register Stock out register Material Return register GIN register(vendor/item/service/job) 	<ul style="list-style-type: none"> Purchase Requisition register Purchase List Register PO Register(supplier/item/import)-open PO Register(supplier/item/import)-close PO register(supplier/item/import/short closed)- Pending PO register(capital/service/job work) Po GIN Report PO/PO Schedule Status register Purchase Statement Purchase Statement Item Wise Purchase Statement (Excise) Purchase Statement Tax Wise Vendor Register(Closed) Vendor Register-Prospective Vendor Register Supplier payment Summary Reconciliation of Sale/purchase Vendor Wise Item Rate Detail Vendor Outstanding register Vendor aging register vendor payment summery Defaulter vendor Payment summery Vendor Rating Report Vendor wise rejection report Vendor -Wise Debit Note Or Credit Note Vendor -Wise VAT Debit Note Or Credit Note Purchase Invoice Register(vendor/item/tax/ import/GIN) Payable Statutory FORM register(C,H etc) Receivable Statutory FORM register(C,H etc) Payable Statutory FORM Item wise register(C,H etc) Receivable Statutory FORM Item wise register(C,H etc) DSA Register PLA register Purchase CST/VAT register Sales CST/VAT register Excise Purchase Details Excise Sales Details RG1/RG23A1/RG23A11/RG23CI/RG23C11 ER1/ER4/ER5/ER6/ER7 ARE-1 CT-1 Cenvat Register Input Cenvat Register Capital Goods Service Tax Credit Register LBT Register Form-IV For Stock raw Material Other Tax Sales/Purchase Duty/Tax Payable/Receivable Report Attendance register OT/Late minutes Register



<ul style="list-style-type: none"> • QA-RM(GRIN) Register • Rejection Note Register • GIN PO Wise Register • GIN Customer Job Wise Register • GIN VC Wise Register • Vendor Reconciliation • Vendor challan (4 5 a) Register • VC(Item Out) Register • BOM Register • BOM revision register • BOM Classification Report • BOM Item Spare Detail • BOM Value Report • Project Register • Product Declaration Register • QA-FG Register • FG Rejection/Rework Report 	<ul style="list-style-type: none"> • Leave Register • Employee Register(new joining/ left/ confirmed) • ESIC Statement • ESCI Challan register • PF Statement • PF Challan • PF Form 3A/10/12A/5 / 10 • Form 16 • Salary Statement • Emolument wise salary register
---	---

18. Sales & Marketing (Advance)

Features	Reports
<ul style="list-style-type: none"> • Sales Executive Master • Executive Visit Report/ Approvals • Business Associates Master • Enquiry Allocation/Enquiry Allocation Status • Estimation format master • Estimation & costing for Proposal • Work order status/Tracking • Order Booking/Blocking • Work order planning • Multiple Order Project group • Sales Projection & plan • Customer Grading • Bank Guarantee 	<ul style="list-style-type: none"> • Sales Executive Info /Register • Sales Executive visit report/ Register • Business Associates Info /register • Enquiry Allocation & status register • Estimation Format Register • Estimation costing Report/ Register • Order booking register • Project Group info /Register • Sales Projection Report • Customer Grade Register • Bank Guarantees Statement/Register

19. Purchase (Advance)

Features	Reports
<ul style="list-style-type: none"> • Purchase Requisition & approval • Purchase List (vendor selection and rate approval) • PO generation from Purchase List • Vendor Enquiry • Vendor Quotation • Quotation Comparison • Vendor Rating & grading • Inter Unit sales & purchase 	<ul style="list-style-type: none"> • Purchase Requisition register • Purchase List/ approval status • Vendor Enquiries register • Vendor Quotation Received register • Quotation comparison statements • Pending Indent Register • Advance Payment Requisition • Vendor rating Reports • Advance Payment Register • PO List pertaining to Budget Control • Inter unit purchase register • Bill wise Items Self Life Statement • Purchase Bill value difference statement

20. Inventory (Advance)

Features	Reports
<ul style="list-style-type: none"> • Formula Master • Material Master • Item location • Stock Transfer Requisition • Stock Transfer • Material Transfer (WIP) • Batch/ serial number Inward & Stock • Location/ section wise Inward & Stock 	<ul style="list-style-type: none"> • Formula register • Material register • WIP stock Statement/ Register • Raw material history card • Profit Center wise consumption • Stock Movement • Stock-Alert-Report(Over-Stock / Under-Stock) • Value Added for Non-Gin(Detail, Summary)



<ul style="list-style-type: none"> • Packing wise Inward & Stock • Material consumption for batch, serial number, packing, location /section • GIN Planning • Sales location stock • Material Safety Data Sheet • Scrap generation Entry 	<ul style="list-style-type: none"> • Third Party Inventory • Department wise consumption • Fast & Slow moving Items • Before Expiry/MFD wise stock • Dump /hold Stock report • Negative Stock report • Stock Life Statement • Manufacturer wise Stock • Barcode wise Stock
--	---

21. Material Planning (Advance)

Features	Reports
<ul style="list-style-type: none"> • Time Phased Material Planning (MRP-II)-Project Based blocking. • Sales Projection Planning (Item Wise, Customer Wise, Monthly Schedule, Amount Wise) • Auto Indent (Work order based) • Reorder Level based planning • RM/ In house /Job material segregation • Work order planning • BOM comparison • Effects of BOM revision in Projects. • Revised project planning 	<ul style="list-style-type: none"> • Material Planning Report • Sales projection report • Segregation planning report • BOM comparison report • Revised BOM History • Project Effect due to BOM Revision Report • Deletion and addition of material in Project Revision

22. Production Management(Advance)

Features	Reports
<ul style="list-style-type: none"> • Machine master • Sequence of operations • Machine scheduling • Work Station Master • Operators • Job Cards/Job Status • Production Slip/Indent • Monthly production planning(SFG/Fg)- monthly/order based/sundry • Project allocation(work station/employee) • Production Update • Multiple Product Declaration • Multi Stage Production Process - Yield calculation Scrap Accounting (Production) • Location-wise Work Order • WIP transfer • Material shortage view • Change of Equipment Load Plan • Production W/o planning (Technical BOM Wise) • Break Down Entry • Shift Allocation (Fixed/ Rotation) • Production Schedule / Reschedule • Material Transfer • Production Overhead Costing • Product Declaration (Project Wise) • Batch / Serial No. Allocation • Product Diversion(RM/SFG/FG) • Rework Indent • Item Process plan (multiple SFG for same item based on operation) • Creation of temporary WIP items based on operations • Estimated and Actual Efforts tracking • Estimates and Actual Material Tracking 	<ul style="list-style-type: none"> • Job cards Printing • Production Indent Report/Register • Machine loading sheet • Daily Production schedule • WIP register • Stage wise Production Plan • Work order wise production plan • Machine utilization register • Plan Vs Actual Production • Shop wise Daily production report (unit wise/ shop wise) • Production Report (part wise, machine wise) • Down time (group wise down time, machine wise down time) • Machine efficiency report (Shift wise, machine wise) • Operator efficiency report • Comparison Report (month wise) • Plant and machine utilization Yearly schedule VS Dispatch • Production line Rejection Report (Date wise) • Work Order Vs Produced • Material & Consumables Consumption • F.G Serial No/Batch Register • Item process plan report / Register



23. Quality Control(WIP)	
Features	Reports
<ul style="list-style-type: none"> • QA-WIP Entry • WIP rejection entry • WIP rework Indent • Sample based QC • Stage wise QC parameter setting 	<ul style="list-style-type: none"> • QA –WIP report/Register • WIP rejection report/register • WIP rework indent register • Test certificates

24. Production scheduling & Capacity Planning	
Features	Reports
<ul style="list-style-type: none"> • Work station capacity loading and scheduling • Workstation planning with manpower • Back ward and forward Re scheduling • Machine/work station capacity identification 	<ul style="list-style-type: none"> • Machine utilization register • Work station Capacity & allocation register • Under utilization report(Machine/workstation/employee)

25. Plant and Machinery Maintenance	
Features	Reports
<ul style="list-style-type: none"> • Preventive Maintenance Schedule • Maintenance Requisition • Maintenance Attendance • Break down entry • Shut down Maintenance & Requisition • In House and Outsource Calibration • Material Indents(Spare shortage) • Machine spare list • Maintenance/service indent/requisition • Repair challan (service) • Spare costs 	<ul style="list-style-type: none"> • Man power/ Spares allocation • Maintenance register(schedule/completion/pending) • Break down register(Pending/Completed/cause/department/ machine / spare/ cost)) • Machine spare list report • Maintenance cost register • Preventive schedules register • Calibration schedule reports • Repair challan register • Maintenance indent register • Preventive Maintenance Activity Check List • Power Factor Date Wise Report • Pending Maintenance Requisition • Pending shutdown Requisition • Pending Shutdown Maintenance (Clearing Received) • Acknowledgement Of Machine Received after shutdown Maintenance • Down Time Analysis • Calibration Schedule & status • Spares Issued For Maintenance • Maintenance Checkpoints • Machine History Card

26. Estimation & Costing	
Features	Reports
<ul style="list-style-type: none"> • Cost factors • Estimation format master • Estimation (enquiry/standard) with or without BOM • Project costing (BOM) • Product costing • overhead Costing 	<ul style="list-style-type: none"> • Estimation format report/ register • Estimation report/ register • Project Costing register • Project costing (actual Vs estimated) report • Project costing deviation due to Revision • Various costing analysis reports like material, process, job, manpower, machine etc • Over head cost register

27. Project Budgeting & Tracking	
Features	Reports
<ul style="list-style-type: none"> • Project entry • Project Budgeting & Planning • Project approval • Project Scheduling & Allocation • Project Tracking 	<ul style="list-style-type: none"> • Project info/ Register • Project status & progress register • Budget vs actual expense • Project Deviation from schedule • Project completion register



28. HR Management (Recruitment/ leave/Training/ Performance Appraisal)	
Features	Reports
<ul style="list-style-type: none"> • Skill Master/Interview Type Master • Job Profile /Vacancy Master • Candidate Information Master • Candidate Performance • Candidate Information Interview Detail • Terms Variable/ Term Head Master • Offer Letter / Appointment Letter • Leave Policy • Leave Application • Leave Adjustment/ Leave Transaction • Training schedules/allocation • Skill updation • Appraisal Parameter/ Parameter Group • Appraisal Setting/Appraisal Approval 	<ul style="list-style-type: none"> • Offer Letter • Appointment Letter • Candidate register (profile wise) • Candidate report (short listed/offered /joined) • Candidates performance sheet • Leave policy register • Leave register • Leave application register (approved/taken/ canceled) • Training register • Employee skill update register • Employee appraisal sheet • Employee left register • Employee increment/promotion report

29. Payroll (Attendance Integration & Income Tax))	
Features	Reports
<ul style="list-style-type: none"> • Import Attendance • Missing Attendance Data • Verify Individual Employee Attendance • Verify Attendance Data • Income Tax Slab • Employee Attendance • Rebate master • Employee Rebate Details • TDS calculation • Income tax data updation • IT Proof document attachment 	<ul style="list-style-type: none"> • Attendance register • Missing attendance register • Employee attendance sheet • Late/OT register • IT Statements • Form 16 • Income Tax Recovery Statement • TDS Statement (Monthly) • TDS Report (Yearly) • Overtime Report

30. Document Management	
Features	Reports
<ul style="list-style-type: none"> • Drawing/design master data maintenance • Drawing /design revision handling • Drawing/ design inward-outward • Attachment & Accessibility of Scanned Documents • Automated Reply • Mass Mailing/Alert configuration 	<ul style="list-style-type: none"> • Log Register • Inward Register • Outward Register • Drawing register • Drawing revision register

31. Export & Import	
Features	Reports
<ul style="list-style-type: none"> • Offer Letter • Export Packing List • Pre Shipment Inspection Intimation • Performa Invoice & Commercial Invoice in foreign currency • Bill of Lading & Shipping Bill • Certificate of Quantity • Certificate of Origin • Certificate of analysis(Quality Certificate) • Bill of exchange • CHA Bill(Invoice) • Shipment /Port Master/Custom House Agent • Cargo Arrival Note • LR Detail/Import Bill Of Entry • Insurance Letter/Letter Of Credit • Import Ex Bond Clearance • Import Accounting (P.O., GIN ,Bill of Entry, C/A 	<ul style="list-style-type: none"> • Certificate Of Origin • Shipping Bill • G.S.P • G.R. Form • AR-4 • Bank Certificate • Daily Stock Register • CT3 Register • B17 Bond Register • Export Register • AR-3A • Shipment • Bonding • LC Application • Statement on status of LC • Stocks at Bond • Advance License Obligation v/s Exported



Bill, Bonding / De-bonding) <ul style="list-style-type: none"> Prepare Performa invoice in equivalent Indian rupees along with AR4 form 	<ul style="list-style-type: none"> Advance License Eligibility v/s Utilized
---	--

32. Asset Management

Features	Reports
<ul style="list-style-type: none"> Asset Group/Asset Master Asset Allocation/ Reallocation /Asset Transfer AMC Master Lease Master/Lease Renewal Asset Complaint/Asset Maintenance Assets Numbering Identified by Barcode / RFID Tag Assets In charge Assets Maintenances Assets on Leased Contract (Warranty, Maintenances, Licenses, Other Services) Assets Depreciation Calculation 	<ul style="list-style-type: none"> Assets Register (Own/ Leased/Group) Assets Allocation Report Assets Maintenances Report Assets Depreciation Report Schedule of Fixed assets as required for Balance sheet as per Schedule VI / ICA guidelines Fixed Assets Register Summery Detailed showing item wise additions Register of Capital WIP items List of additions with names of vendors installation dates, break up of values List of deletions /List of Write offs during year List of items used for addition to capital assets Statement of exchange gain loss on capital assets Department wise asset issue status

33. Advanced Finance Management- (Budgeting, Forecast, RFC, ratio Analysis etc)

Features	Reports
<ul style="list-style-type: none"> 3 instance budget and forecast Cost Center wise Budget Budget v/s Actual Over Budget Expenses Statement Budget/Account Details Capital Employed Allocation Return On Capital Employed Ratio analysis Budgets / Targets / Credit Limits 	<ul style="list-style-type: none"> Five year sales forecast report Rolling forecast report Budget vs actual trial balance /P&L/Balance sheet New production forecast report ROI Ratio analysis reports Budget deviation explanation report

34. Capital Project Management

Features	Reports
<ul style="list-style-type: none"> Activity Master/Action Master Capital Project / Sub Project entry Capital Phase /sub phase Master Capital Project Budget Head Master Capital Project Costing Factor Capital Project Budgeting & Planning Capital Project approval Capital Project Scheduling & Allocation Capital Project Tracking 	<ul style="list-style-type: none"> Capital Project info/ Register Capital Project status & progress register Capital Budget vs actual expense Capital Project Deviation from schedule Capital Project completion register

35. Security & Gate Pass

Features	Reports
<ul style="list-style-type: none"> Visitors appointments Visitors In/ Out Employees In/ Out Contractor schedule Contractual employees IN/ Out Material In/ Out 	<ul style="list-style-type: none"> Visitors gate pass Authority wise visitors reports Customer / Supplier wise visitors reports Appointment taken but not visited report Material In & out Register Contractor schedule List Contractor attendance summery



36. Service & Installation Management

Features	Reports
<ul style="list-style-type: none"> Service Executive Master Service work order generation (complaint & service OA) Service Task Allocation/Service Task Status Service (Production) Indent New BOM for service Executive Visit Approval Service Invoice generation Material requisition for service 	<ul style="list-style-type: none"> Service executive register Service work order register Task allocation register (customer/executive) Service indent register Service bom register Executive Visit Report/ register Material issue/used report Service task status report

37. Logistics & warehouse Management

Features	Reports
<ul style="list-style-type: none"> Ware House Master (Owned/ Leased) Delivery Order CAD (Stock Transaction from warehouse) Bank Receipt Order Fright Forward Master Ware House Stock Maintenance Authorization of receipts to Warehouse Stocks at Third Party warehouse 	<ul style="list-style-type: none"> Ware House Register (Lease / Own/ Vendor/ Capacity / Location) Delivery Order Detail (Vendor/ Product/ CAD) Bank Receipt Order Freight forwarder register FF invoice register

38. CRM/SCM

Features	Reports
<ul style="list-style-type: none"> Dashboard to view Party info Order tracking Complaints Complaints Allocation and Closing Material delivered status Payment details 	<ul style="list-style-type: none"> Order Status view by Party Complaint / Call Logging Logging all complaints as well as logging all incoming and outgoing calls. Allocating complaints to concerned departments / person Tracking of complaints action taken reports

39. Dealer/Distributor Management

Features	Reports
<ul style="list-style-type: none"> Dealer /distributor master Dealer product rate/discount details Dealer order booking and scheduling Offers and schemes Dealer invoice Dealer stock details 	<ul style="list-style-type: none"> Dealer register Dealer product rate register Dealer order register Dealer invoice register Dealer collection report Dealer stock movement register

40. Tender Management

Features	Reports
<ul style="list-style-type: none"> Various Types of Tender Document (Tender Notice, Tender Form, Rate List) Maintain Tender Enquiry Tender Follow up Tender Form with Annexure Attachment Agreements 	<ul style="list-style-type: none"> Tender Enquiry Register (Source/ Type / Product/ Customer / Schedule) Tender Register (Source/ Type / Product/ Customer / Schedule) Tender Follow-ups (Product/ Customer/ status) Tender status register (Received/ Cancelled)

41. Event Management

Features	Reports
<ul style="list-style-type: none"> Event Type Event Sub Type Event Role 	<ul style="list-style-type: none"> Event Type register Event Sub Type Register Event Role Register



<ul style="list-style-type: none"> • Event Master • Event scheduling & budgeting • Event Execution 	<ul style="list-style-type: none"> • Event Master Register • Event Execution Register • Expenses budgeted v/s actual
---	---

42. Resource Management

Features	Reports
<ul style="list-style-type: none"> • Resource Data Maintenance • Confirmation Trough E-mails • Booking of Resources • Resource Maintenance • Resource Allocation • Advanced Search Capabilities • Flexible Time Management 	<ul style="list-style-type: none"> • Resource Register • Resource Booking Register • Resource Allocation Register • Resource booked but not attended • Resource Idle register • Resource Usage Register • Booking Cancellation Register

43. Advance MIS

Features	Reports
<ul style="list-style-type: none"> • Sales analysis report (executive/zone/region/product) • Business associate sales register • Enquiry allocation registers (Executive/service/product) • Enquiry status register • Estimation registers (enquiry/product) • Order booking and blocking register • Bank guarantee register • Bank guarantee renewal/expiry report • Sales projection report (value/customer/product) • Actual v/s projection sales report • Customer grading report • Customer grade comparison report (last 3 years) • Customer List whose credit limit exceeded • Product sales summery (Top 5/ Bottom 5) • Product (Spare) sales (Top 5 & Bottom 5) • Customer sales summery (Top 5/ Bottom 5) • Customer in time payment receipt (Top 5/ bottom 5) • Timely delivered Order Register • Delayed Order Register • Diverted work order register • Orders closed below estimated cost • Order value Deviation from estimated cost • Order lost due to high estimation • Order lost due to Technical infeasibility • Emergency Purchase Requisition • Material Purchase summery (Top 5/ Bottom 5) • Purchase summery (Top 5/ Bottom 5) • Vendor enquiry registers (Item/Project) • Vendor quotation registers (Item/Project) • Vendor quotation comparison chart (price/ delivery/ terms/ landed cost) • Vendor quotation short listed • Vendor rate comparison (price / landed cost) • High value purchase register • Maintenance material purchase register • Consumable material purchase register • Capital goods purchase register • Inter unit purchase register • Inventory Ageing Analysis • Cost Center wise Consumption • Stock Reserved (Block) register 	<ul style="list-style-type: none"> • BOM Revision Cost Comparison • Cost effect of BOM Revision on project • Revised project planning register • Planned schedule v/s actual PO date • Planned v/s actual Item quantity(Project) • Blocked/transition blocked/ Purchase reserve item list (project) • Project Health/status • Various project analytical reports • Batch/project-Costing • Capital project status and investments • Budget vs Actual • Product Diversion(RM/SFG/FG) • Planned v/s production • Rescheduling of In house to outsource • Efficiency report (machine /workstation) • Capacity/ actual load report • Rescheduled project report • Least product rework (Job Work / Sub-contracting) • In time production register • Delayed production register • Product complaint register • Product rework Register (Job Work) • Parameter wise QA reports • Rejection and rework analysis • Break down analysis register • Down time effect report • Down time loss report • Rescheduled production report(down time) • Maximum Machine efficiency List • Product cost analysis • Estimated and actual cost analysis • Customer wise product cost analysis • Bom revision cost deviation report • Project planned vs actual report • Project diversion analysis report • Project budget analysis • Project material analysis • Project man power analysis • Employee transition analysis report • Employee performance variation report • Asset Maintenance Cost register • Employee performance Details • Employees having 100% attendance • Employee with maximum absenteeism



- Alternate (substitute) item list
- Stock of end pieces (re usable stock)
- List of Material (vendor/customer) in Transit
- Moving and non moving Item Register
- Item register (batch/serial no)
- Material safety checklist
- Stock transfer register(Inter unit)
- Excess items issue list(Project/ workstation)
- Near Expiry Stock report
- Stock Aging Analysis
- Various Analysis reports (ABC etc.)
- Rate Difference Stock List on New Rate/ MRP/ Sale Rates/MRP wise Purchase/MRP=0
- Ware house analysis report (capacity vs occupancy/product/maintenance)
- Dealer sale Register (Top5/ Bottom5)
- Dealer performance analysis report(sales/ payments)

- Late comers list
- Maximum Over time list
- Employee income tax /TDS analysis report
- Employee income tax document proof report
- Export analysis report (product/currency rate)
- Import analysis report (material /landed cost)
- Capital goods /assets value analysis report
- Budget v/s actual analysis report
- Sales forecast analysis reports (new /old product/RM cost/development cost/profitability)
- Various ratio analysis reports
- Capital project track report
- Capital project deviation report (cost/time /efforts)
- Service work order analysis report (status/cost/schedule)
- Tender filed & awarded analysis report